

Sump Entry/Termination Fitting with
Bonded Fiberglass Alignment Rings

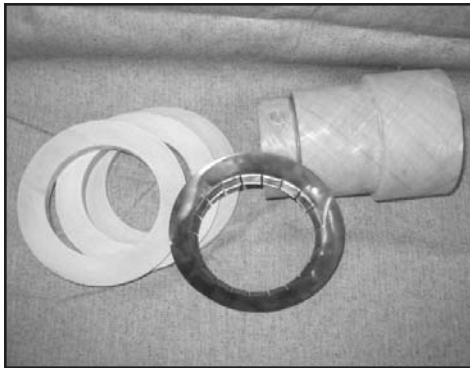

2. Using 40-60 grit sanding surface, sand the area around the hole where the alignment rings will bond to the sump. Lightly sand the rings. Remove dust and wipe with solvent (optional).
3. Place two alignment rings on sump entry/termination fitting and insert through sump wall with the

- rings on the outside of the wall. Locate the 1/4" threaded outlet to the desired location. Leave 1/4" plastic threaded outlet protector in place until 1/4" fitting installation.
4. Dry fit primary pipe and rotate the two rings until the desired angle is reached. Make alignment marks on the rings and the sump wall.

Note: Fiberglass alignment rings can only be bonded to a flat fiberglass surface. DO NOT install on round sumps.

1. Determine entry hole location and cut entry hole in sump wall using dimensions in Table 1. (Maximum allowable offset is 5°.)

TABLE 1. Fitting Dimensions

Size (in.)	A (in.)	B (in.)	C (in.)
3x2	6.83	4.00	4.00
4x3	6.83	4.00	5.00

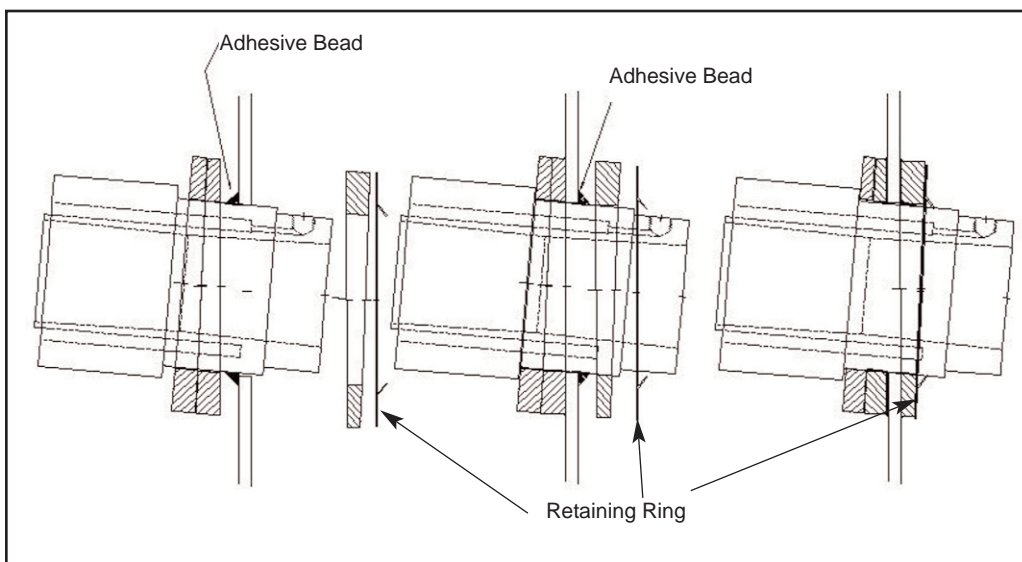
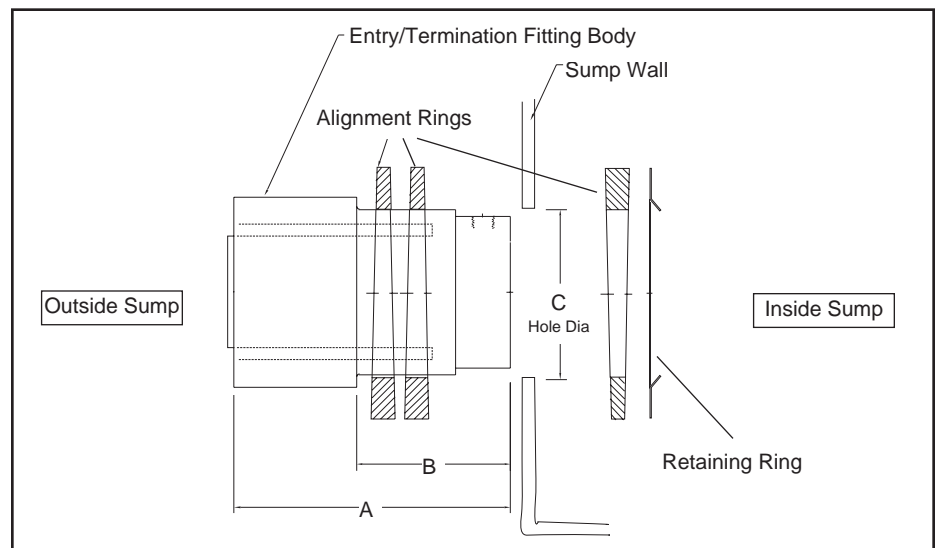

5. Place one ring over the sump fitting in the inside of the sump and rotate to the desired angle. Make alignment mark on both the sump wall and the ring.
 6. Mix one 7014 or 8014 adhesive for each fitting per the instructions in the adhesive kit. Mix in filler to thicken adhesive (**fiberglass alignment ring will not seal properly without filler**).
 7. Apply adhesive generously, approximately 1/16" thick to the inside and the
- (over)*

Sump Entry/Termination Fitting with Bonded Fiberglass Alignment Rings

outside of the sump walls where the alignment rings are located. Apply a thin coating of adhesive to the bonding surface of the two rings that will bond to the sump walls.

8. Line up rings with alignment marks and press together firmly.
9. Slide the metal retaining ring over inside section of sump fitting against the alignment rings until they are tight against sump wall. (A short section of 4" pipe may be used to drive the metal retaining ring over the fitting.) **Be sure there is an adhesive bead visible between the rings and the**

sump wall. The metal ring must hold the assembly in position while the adhesive cures. If the assembly is not tight against the sump wall, firmly press the entry fitting against the outside sump wall while pressing the metal ring against the alignment ring on the inside.

10. Do not disturb assembly until the adhesive is cured. This includes bonding of pipe to the entry fitting and installing the threaded outlet fitting. Clean excess adhesive from all bonding surfaces. See adhesive kit instructions for cure times.

11. The use of an industrial hot air gun may speed up the curing process. Do not overheat.
12. Remove 1/4" plastic threaded outlet protector. Apply adhesive to the 1/4" fitting and screw into the 1/4" threaded outlet. Tighten to 40 in.-lbs. or 1 1/2-2 turns past hand tight. After installing fitting, be sure the interstitial space is free from excess adhesive. Install a short hose and blow excess adhesive through the air passage.
13. Connect only flexible tubing or hoses to the 1/4" side-outlet. Note: tubing or hoses must be rated to full vacuum.

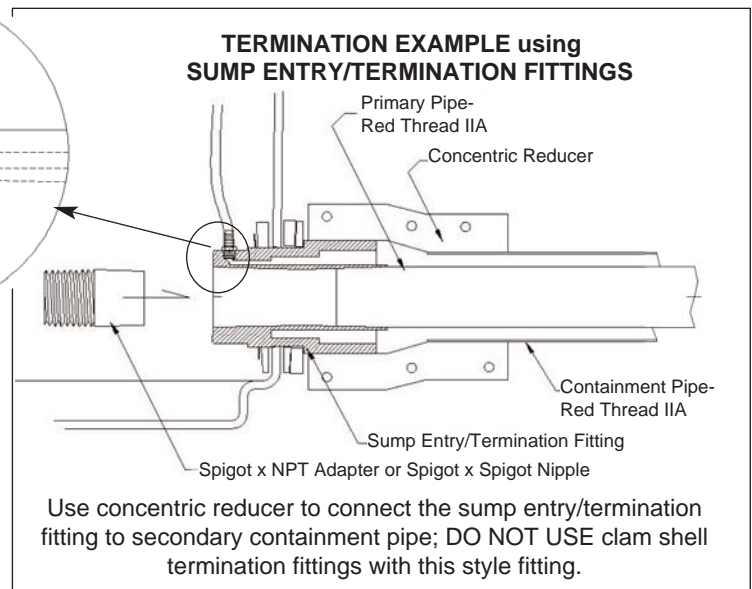
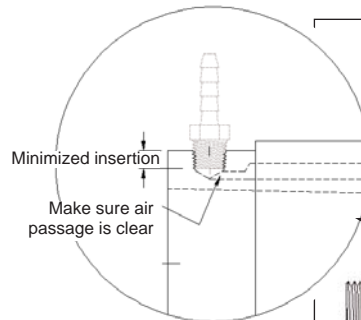
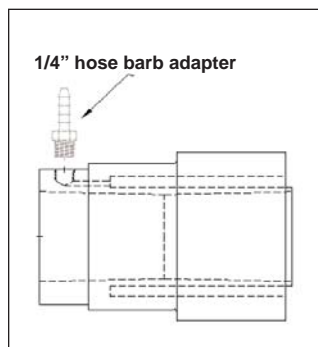

- The 1/4" threads are a "modified NPT" --the insertion of a standard spec male thread is minimized.
- Smith Fibercast 7014 or 8014 adhesive is recommended.
- The 1/4" female threads are plastic and cannot be tightened the same as a metallic thread. Tighten to 40 in.-lbs. or 1 1/2 - 2 turns past hand tight.
- After installing a 1/4" NPT fitting, the passageway(s) to the piping interstitial space should be cleared with air pressure to insure that they are free of thread sealant and/or adhesive.

It is the policy of Smith Fibercast to improve its products continually. In accordance with that policy, the right is reserved to make changes in specifications, descriptions, and illustrative material contained in this bulletin as conditions warrant. The information contained herein is general in nature and is not intended to express any warranty of any type whatsoever, nor shall any be implied.

Fiber Glass Systems™

A Varco Company

SMITH FIBERCAST DIVISION

2700 West 65th Street
Little Rock, AR 72209
Telephone (501) 568-4010
Fax (501) 568-4465
www.smithfibercast.com

